



commercial 2000

The **2000 Commercial Series** is the traditional rolling steel door. Used in a variety of field applications, it provides an economical alternative to sectional or slat doors. Installation is quick and the cam action device allows for easy adjustment of the springs simultaneously. Backed by a one year warranty, the 2000 series is a solid investment for commercial door usage.



**Maximum
12' x 16'**

Available in sizes up to 12' x 16' and in more than 30 colors, customized for your application.



**Light-Duty
Application**

Ideal for light-duty locations, such as boat and RV storage and commercial/ industrial buildings.



**Quality
Guaranteed**

One-year door warranty. For paint, 35-year no-fade, 40-year film integrity.



**Vision Panels
Available**

Vision panels provide outside visibility through the 5" x 17" panel.

COMMERCIAL



Features

- » **Pre-Lubricated Springs**
During production, springs are factory lubricated and enclosed in a tube to protect them from the environmental elements.
- » **Dead Axle & Barrel Assembly**
An enclosed spiral barrel houses the dead axle assembly and offers durability and smoother operation as weight is distributed throughout the barrel.
- » **26-Gauge Corrugated Door Curtain**
Manufactured from galvanized grade 80 steel and coated with super durable polyester paint in more than 30 color options.
- » **Insulated Version Available**
Side and top draft stops included.

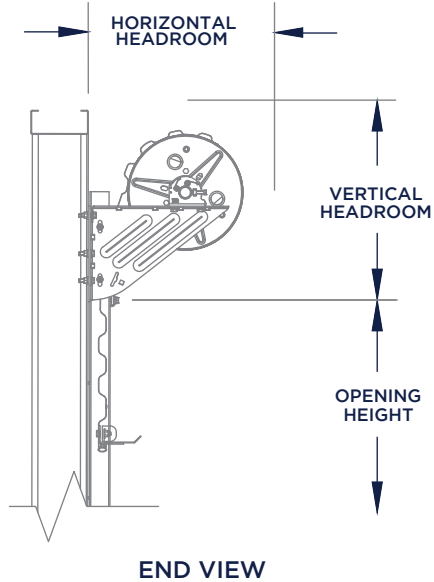

IMPORTANT NOTES:

- Dimensions are referenced from edge of opening.
- Tensioner end and drive end can be installed at either end of door assembly.
- FOR CRITICAL FITS DUE TO REDUCED AVAILABLE HEADROOM or SIDEROOM CLEARANCES, CONSULT FACTORY.

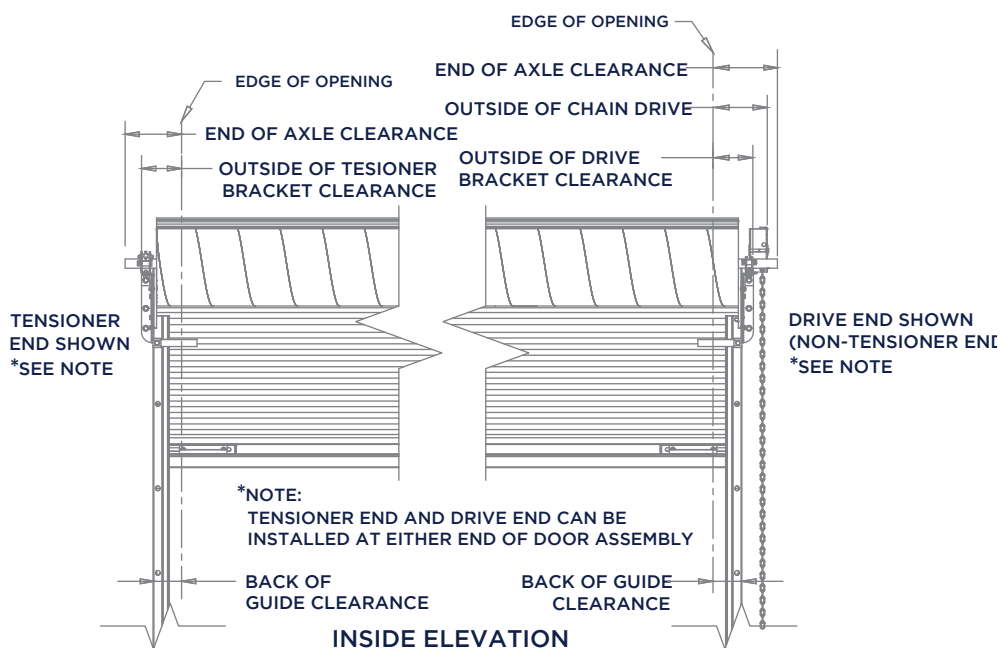

Universal mount 2.25" deep 16-gauge galvanized steel guides require no pre-installation modifications for wood, steel, concrete or filled masonry block applications.

SPECIFICATIONS

Guide Details

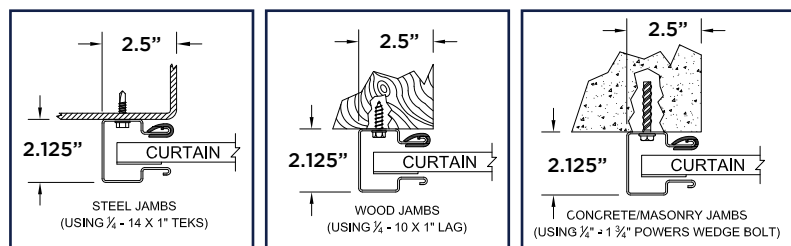

Head Room Requirements

Opening Height	Vertical Headroom	Horizontal Headroom
Thru 8'0"	20"	20"
Over 8'0" thru 10'0"	21"	21"
Over 10'0" thru 14'0"	21.5"	21"
Over 14'0" thru 16'0"	22"	21"
Over 16'0" thru 18'0"	22"	22"
Over 18'0" thru 20'0"	22"	22"

Side Room Requirements

Operation	Guide	Outside of Bracket Tensioner End	Outside of Hand Chain Drive	Outside of Bracket Drive End	Each End of Axle
Push Up	2.5"	4.5"	N/A	4.5"	7"
Reduced Drive Chain	2.5"	4.5"	6.5"	5.5"	7"
Electric	2.5"	4.5"	N/A	6"	7"

HIGHLIGHTS:

- B** Barrel: 12"
- G** Guide: 2.25", 16-gauge
- Ⓜ** 5:7:1 reduced-drive chain hoist offers smoother operation on doors over 10' tall.

Visit rollupdoorsdirect.com for technical drawings, color options and more.